

The background of the page is a detailed technical line drawing of a hydraulic drill rig, showing various components like the mast, motor, and drill bit. The drawing is rendered in a light blue color against a white background. A large, semi-transparent blue circle is overlaid on the drawing, framing the central text. In the top left corner, there is a solid blue square. The company logo 'HÜTTE BOHRTECHNIK' is positioned in the upper left area, with 'HÜTTE' in a large, bold, blue font and 'BOHRTECHNIK' in a smaller, blue font below it. To the right of the text are three stylized blue shapes: a horizontal bar, a downward-pointing arrow, and a curved line.

HÜTTE
BOHRTECHNIK

HBR 203-3

Hydraulisches Bohrgerät
Hydraulic drill rig

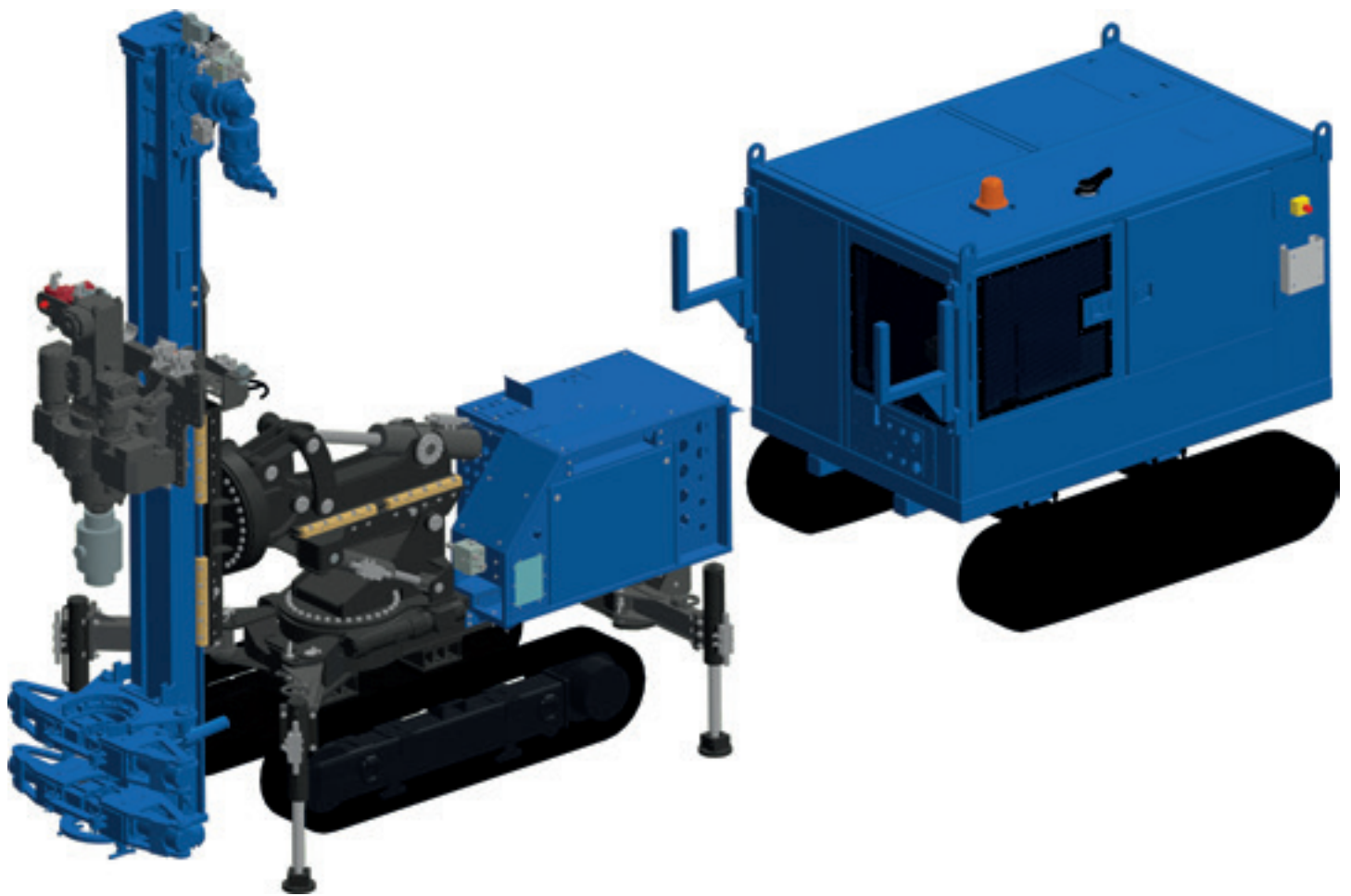

Technical specifications / Technische Daten

Machine crawler base	Raupenfahrwerk Maschine		
Overall width of undercarriage	Gesamtbreite	780/1200 mm	30.7/47.2 in
Track shoes width	Kettenbreite	250 mm	9.8 in
Overall tracks length	Länge der Fahrschiffe	2175 mm	85.6 in
Travel speed	Fahrgeschwindigkeit	1,5 km/h	0.9 mph
Max. gradeability	Max. Steigfähigkeit	20°	36%
Ground pressure	Bodendruck	79 kPa	11.4 psi

Powerpack Engine	Antriebsaggregat Motor		
Deutz - Diesel engine	Deutz - Dieselmotor	TCD 3.6 L04 - EU Stage V - US EPA Tier IV - Final	
Rated power at 2200 rpm	Leistung bei 2200 U/min	100 kW	134 HP

Optional engine with exhaust emission in accordance with EU Stage 3A is available for less regulated markets

Für weniger regulierte Märkte ist optional ein Motor mit Abgasemission gemäß EU Stufe 3A erhältlich

Fuel tank capacity	Dieseltankinhalt	140 l	36 gal
Hydraulic oil tank capacity	Hydrauliköltankinhalt	280 l	73 gal

Clamping and breaking devices	Klemm- und Brechvorrichtungen	CB2	MM2-MM2Z
Diameter	Durchmesser	67÷254 mm 2.6÷10 in	40÷159mm 1.6÷6.2 in
O-Ring type diameter	Durchmesser O-Ring	89÷254 mm 3.5÷10 in	-
Clamping force	Klemmkraft	235 kN 52,800 lbf	157 kN 35,300 lbf
Breaking torque	Brechmoment	30 kNm 22,100 lbf-ft	22 kNm 16,200 lbf-ft

Hydraulic hammer	Hydraulikhammer		
Recommended	Empfohlen	RH10X - RH16X	

Rotary heads	Kraftdrehköpfe		
Recommended	Empfohlen	HG13 - HG20 - T14 - T20	

Options	Optionen		
Cat head	Turmkrone		
Lateral slide	Gleitschlitten seitlich verschiebbar		
Winch type A1 - Fmax	Winde Typ A1 - Fmax.	10 kN	2,248 lbf
Flushing pump type Dynaset HPW220	Spülpumpe Typ Dynaset HPW220	220 bar / 35 l/min *	3,190 psi / 9.34 gal/min
Flushing pump type Dynaset HPW90	Spülpumpe Typ Dynaset HPW90	90 bar / 85 l/min *	1,300 psi / 22.4 gal/min
Casing crane	Gestängekran		

* Reduced water flow capacity with 50 l/min oil flow

Reduzierte Wasserdurchflussmenge bei 50 l/min Hydrauliköl

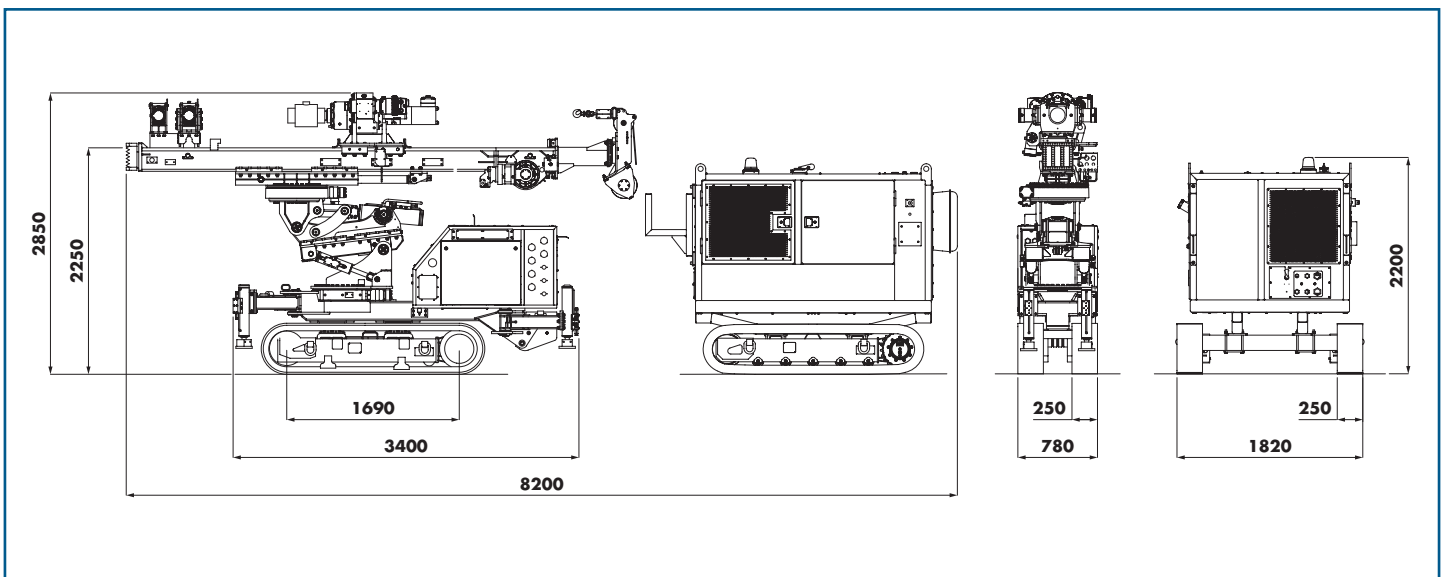
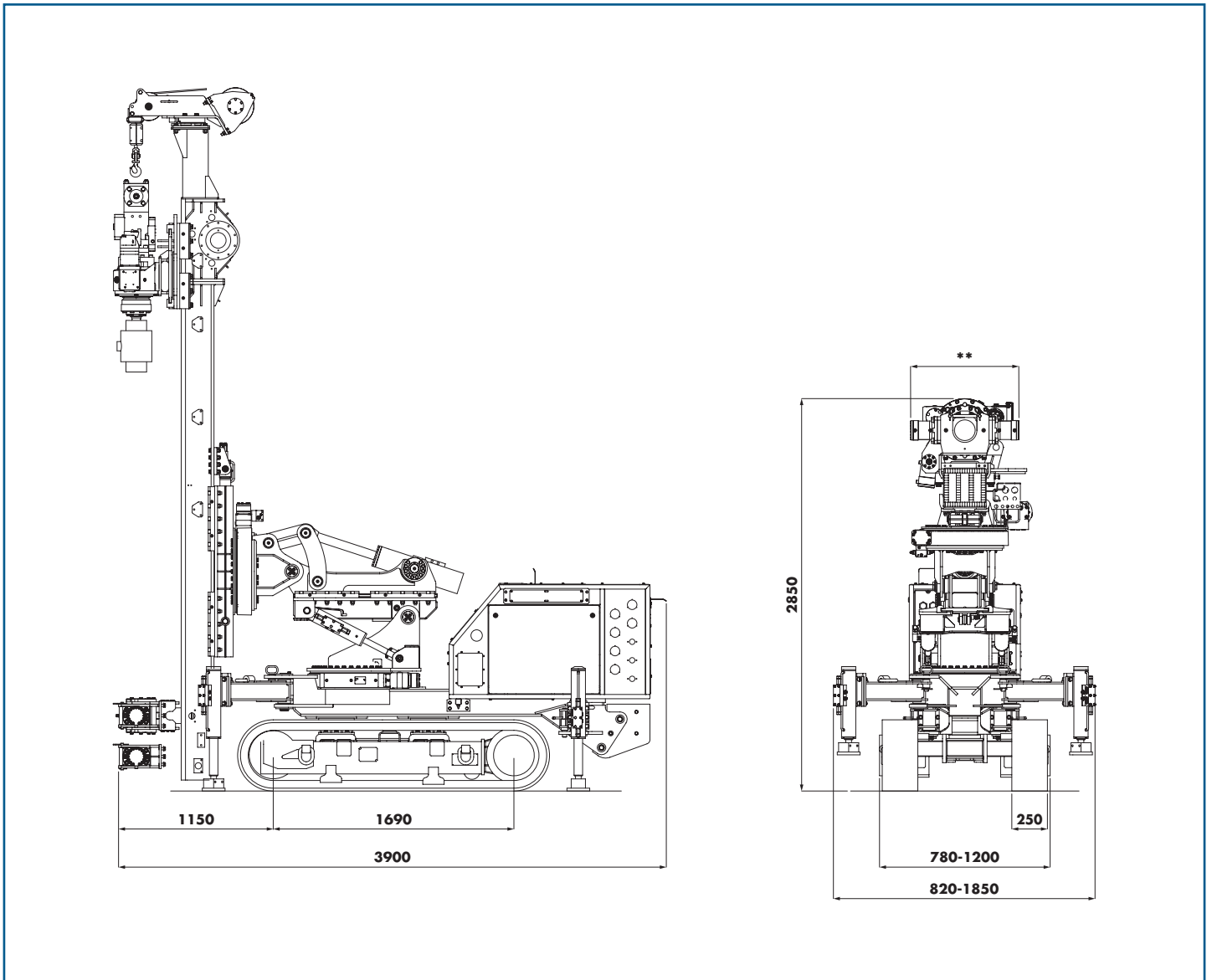

Machine overall weight *	Maschine Gewicht *	6700 kg	14,771 lbs
Power Pack overall weight	Antriebsaggregat Gewicht	3500 kg	7,716 lbs

* Depending on mounted equipment | Abhängig von der Geräteausrüstung

Standard

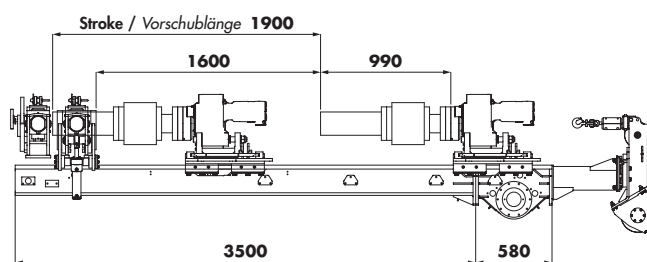
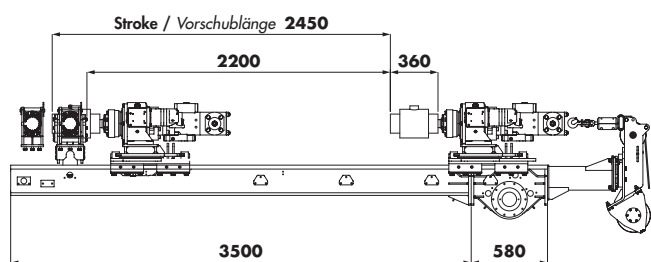

Optional A

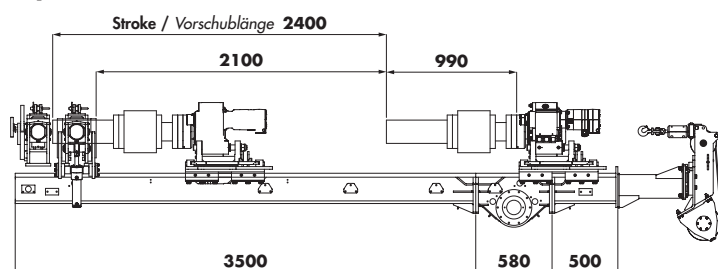

Mast extension	Mastverlängerung	500 mm	19,685 in
Only for vertical drilling	Nur für vertikales Bohren	± 15°	± 15°

Optional B

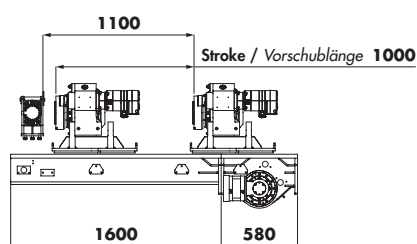
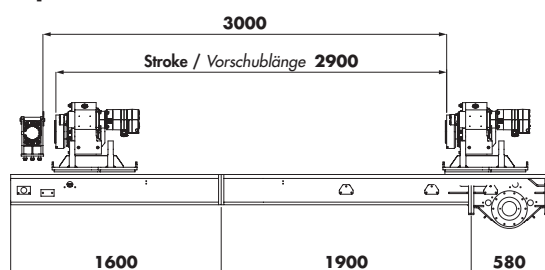

Drill mast	Bohrlafette		
Extraction force	Rückzugskraft	50 (60)* kN	11,240 (13,500)* lbf
Crowd force	Vorschubkraft	50 (60)* kN	11,240 (13,500)* lbf
Work crowd / extraction speed	Vorschub- /Rückzugsgeschwindigkeit	8,5 m/min	27,8 ft/min
Fast crowd / extraction speed	Vorschub- /Rückzugschnell	40 m/min	131 ft/min

* Non CE markets / Nicht CE-konforme Märkte

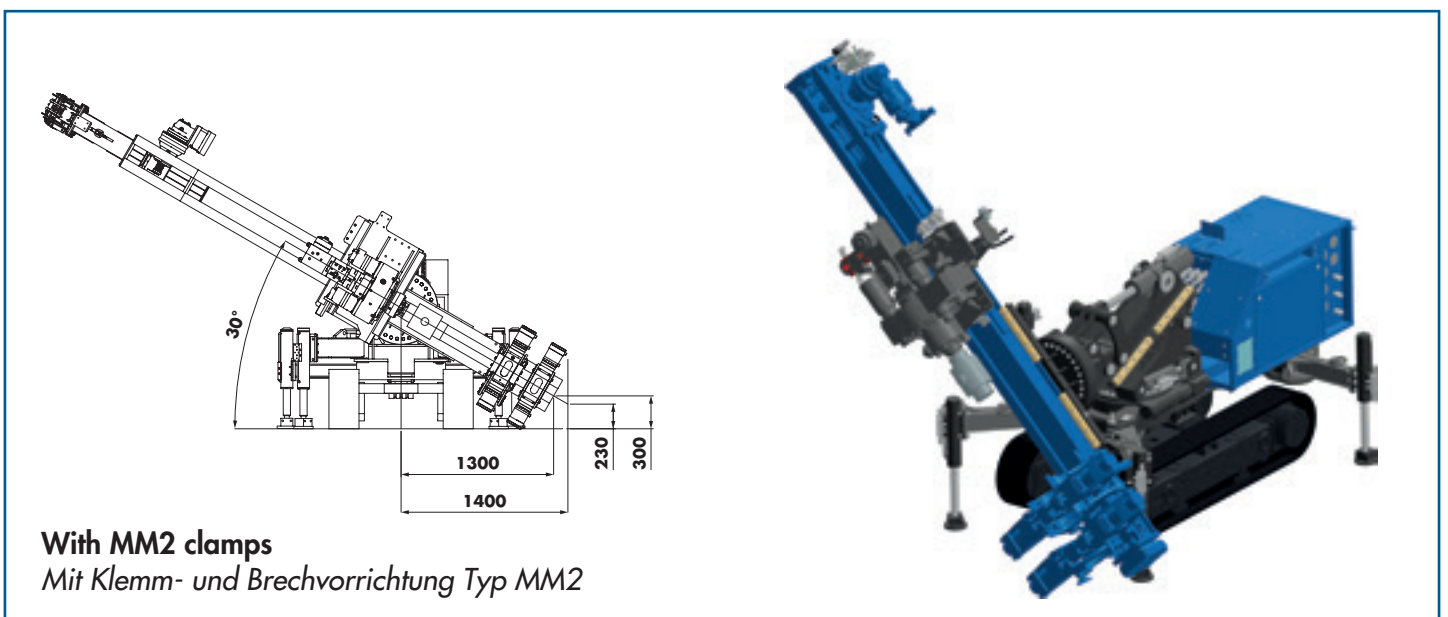
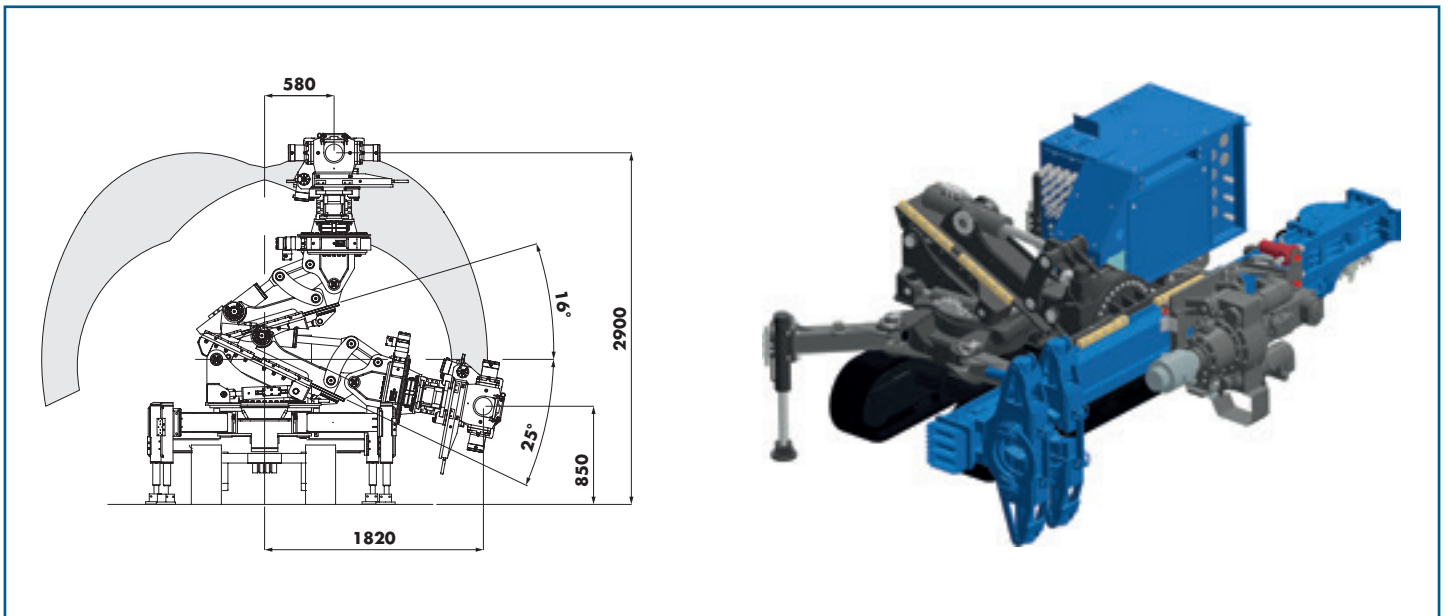
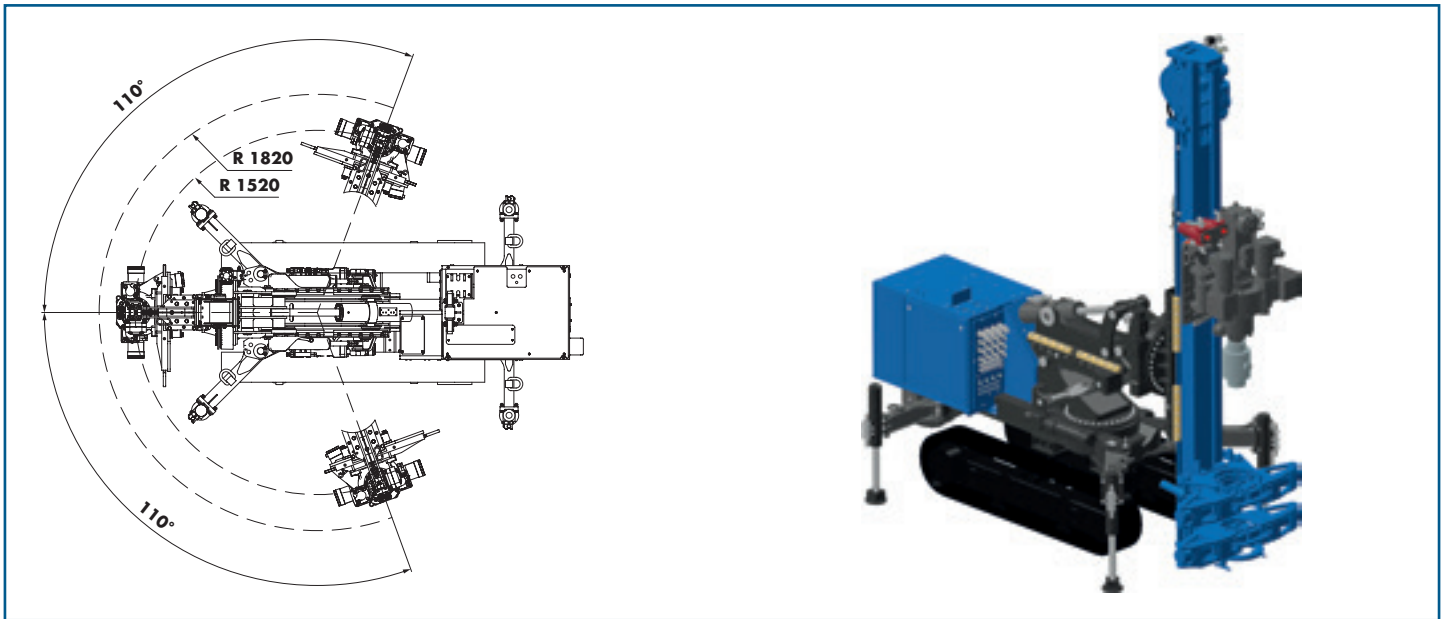

Cat head
Turmkrone

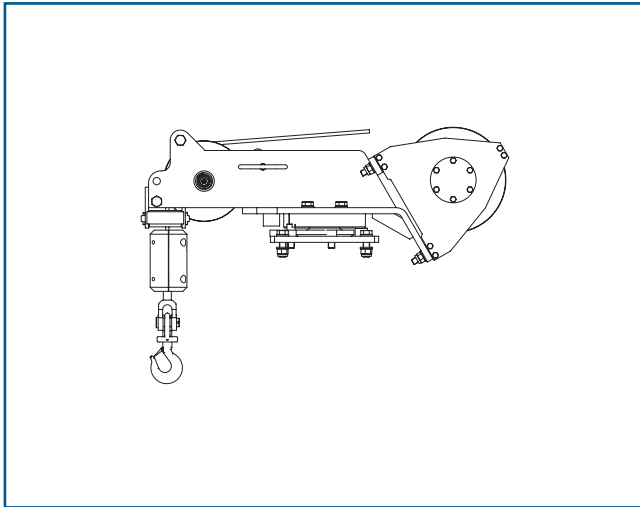

Winch - 10 kN
Winde - 10 kN

Lateral slide
Gleitschlitten seitlich verschiebbar

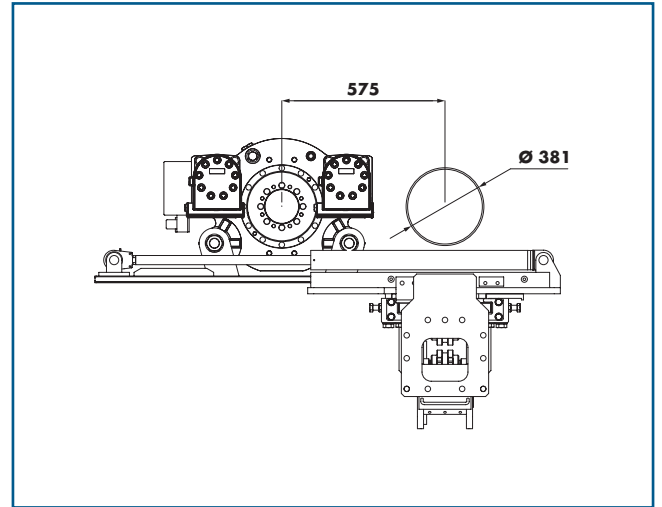

All data contained in this brochure are indicative and does not take power losses into account. All data can be changed without notice.

Technische Änderungen ohne Vorankündigung und Verpflichtung gegenüber früher gelieferten Geräten. Die abgebildeten Geräte können Sonderausstattungen haben. Irrtum und Druckfehler vorbehalten.



Hütte Bohrtechnik GmbH

Ziegeleistraße 36
D-57462 Olpe/Biggesee
Germany
Tel.: +49(0)2761/9644-0
Fax: +49(0)2761/63852
info.huette@casagrandegroup.com

www.casagrandegroup.com

casagrande
group 